

UF-2

Tapa y marco doble modelo Unión Fenosa

Fundición dúctil
Fábregas

ISO 9001
BUREAU VERITAS
Certification

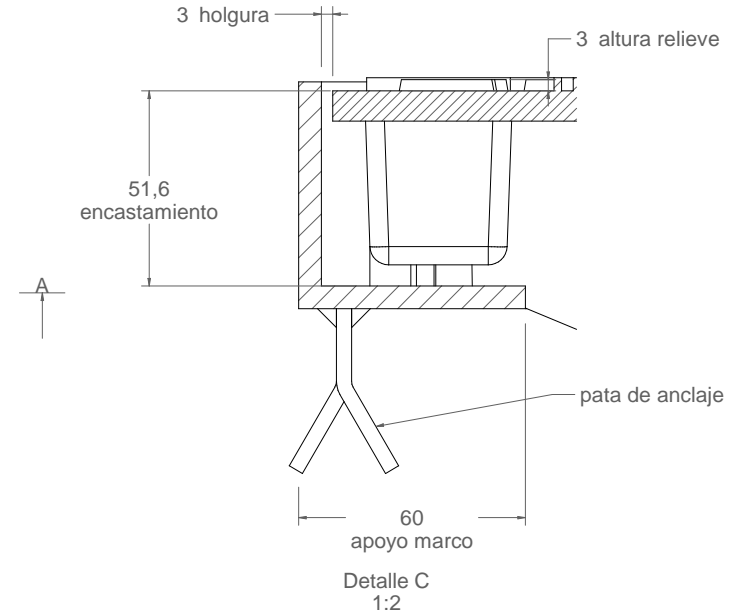
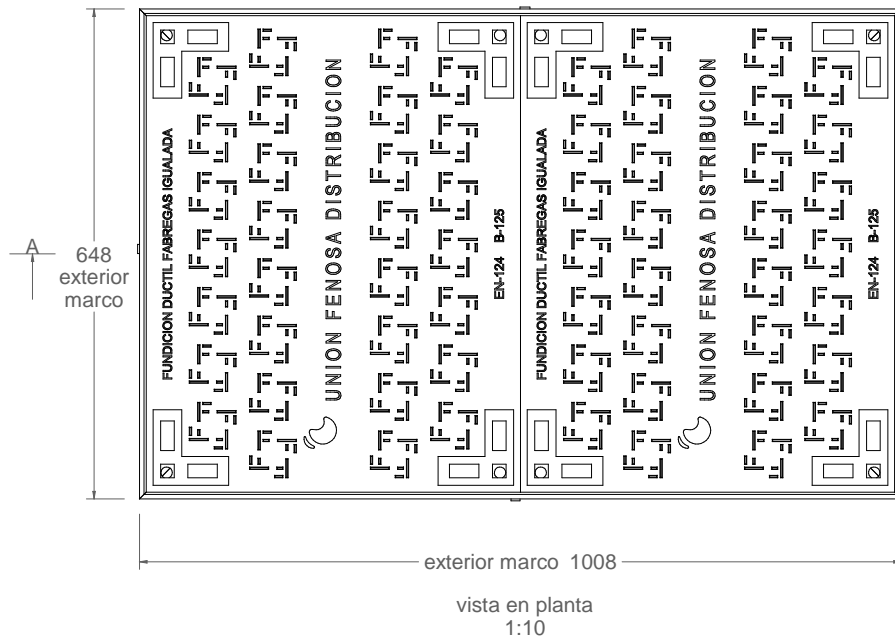
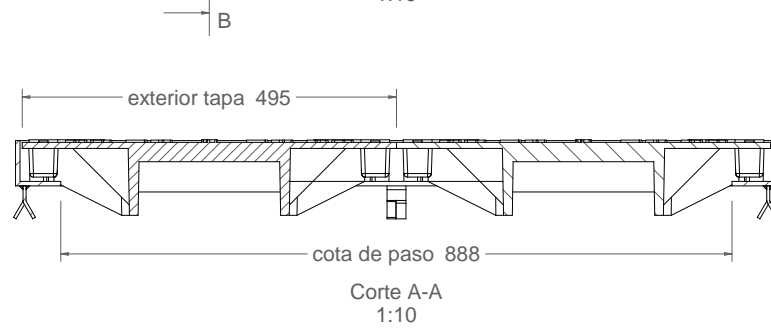
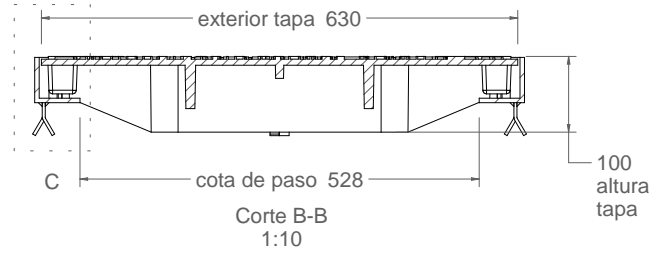
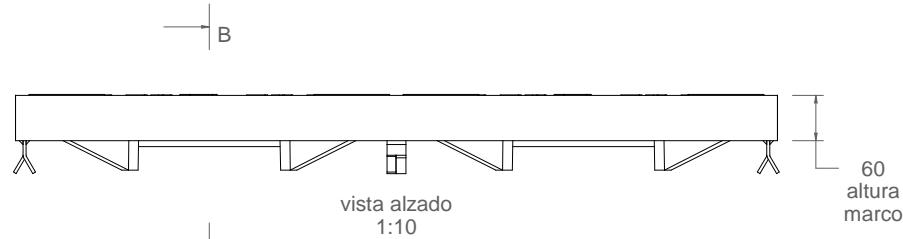
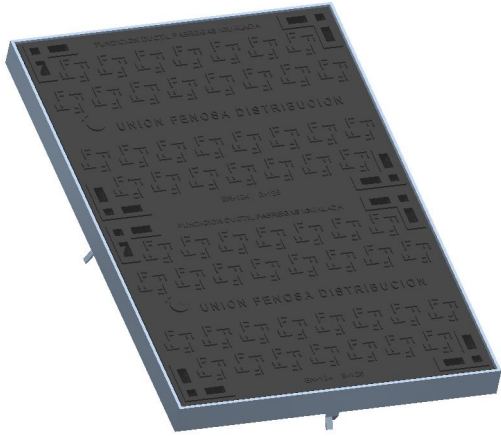

Material:

Tapa: Fundición dúctil GGG40
Marco: Acero galvanizado

Peso: 85.00 kg

Acabado: Pintado negro asfáltico

Norma: UNE EN-124

Clase: B-125

WWW.GRUPFABREGAS.COM