

P-16

Imbornal prefabricado de hormigón H200 de 870x470x1000 mm. CON SOLERA y salida lateral Ø340 mm.

Revision: 01 - 07/12/2020



Descripción: Imbornal de hormigón destinado a la recogida de aguas pluviales.

Material: Hormigón prefabricado H-200.

Detalle de colocación tabica sifónica

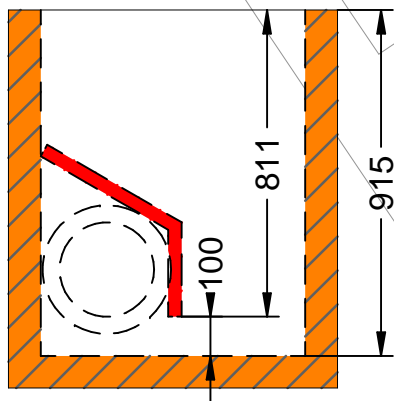

Vista frontal

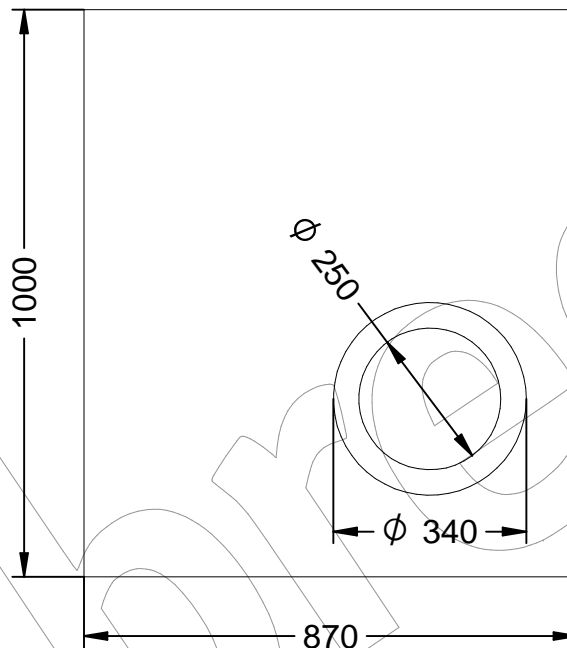

La ventana solo esta en la cara frontal del imbornal.

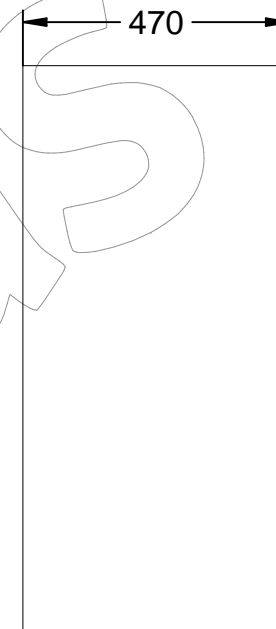

Tabica sifónica 70x30 cm (Incluida en el imbornal)

