

ENCH-8A

Juego eco biosaludable "LA CINTURA".

Revision: 01 - 21/03/2017



- ES-  Zona de seguridad
- CA-  Zona de seguretat
- EN-  Security zone

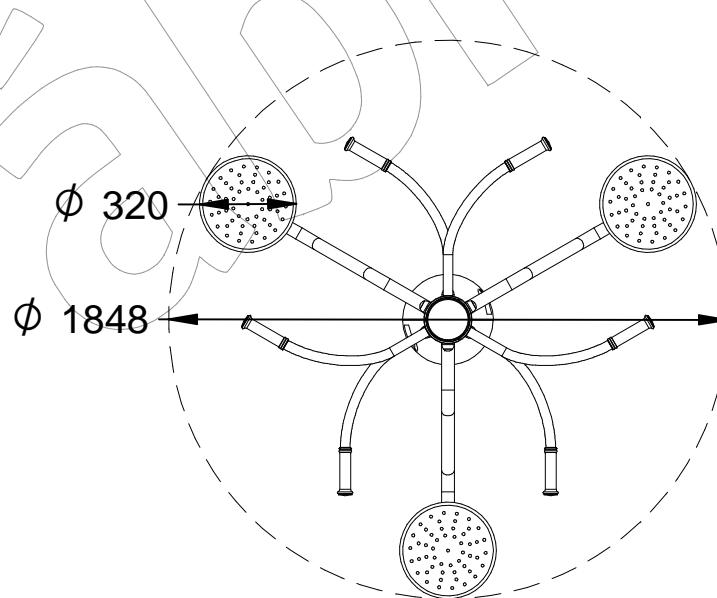
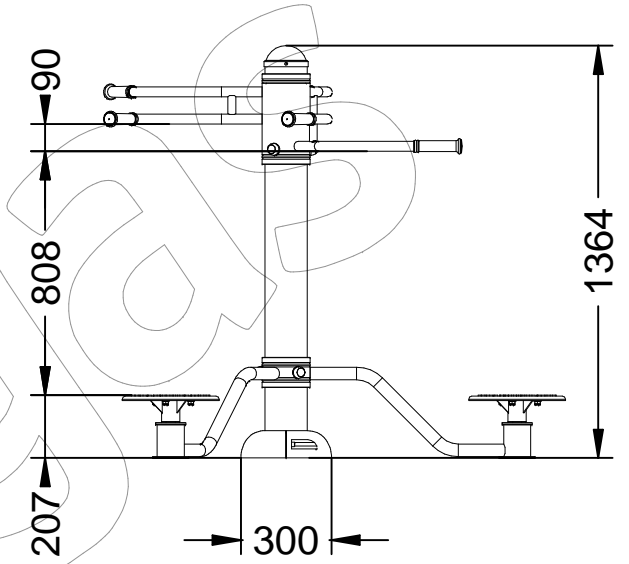
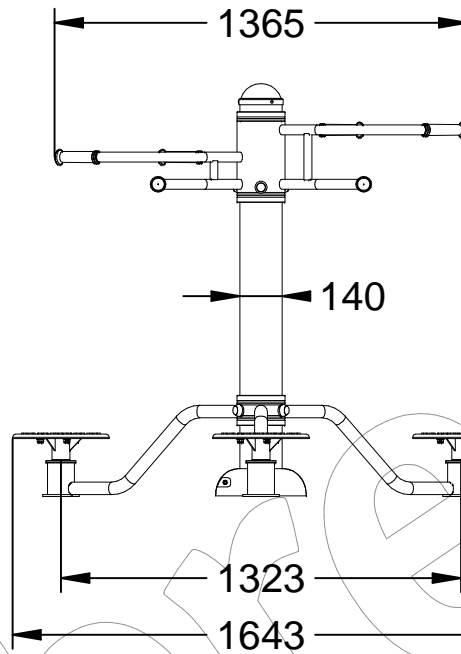
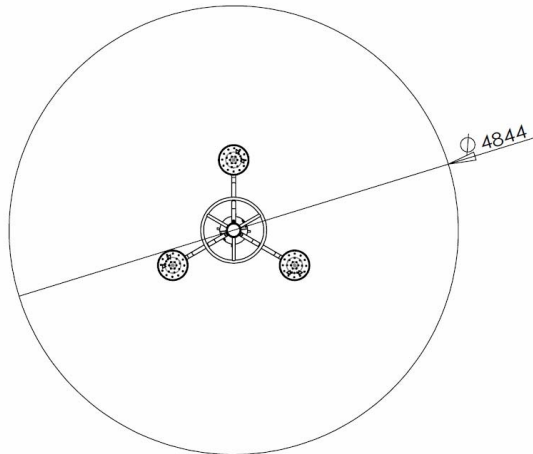

ENCH-8A

Juego eco biosaludable "LA CINTURA".

Revision: 01 - 21/03/2017



-ES- 

Refuerzo de la musculatura abdominal y lumbar, mejorando la flexibilidad y agilidad de la columna vertebral y articulación de cadera.

Bueno para mejorar la cintura.

Medidas: \varnothing 1.848 x 1.643 x 1.364 mm.
Zona de seguridad: \varnothing 4.844 mm.

-EN- 

Strengthening the abdominal and lumbar muscles, improving flexibility and agility of the spine and hip joint .

Good for improving the waist.

Measures: \varnothing 1.848 x 1.643 x 1.364 mm.
Security zone: \varnothing 4.844 mm.

-PT- 

Fortalecimento dos músculos abdominais e lombares, melhorando a flexibilidade e agilidade da coluna vertebral e articulação do quadril.

Bom para melhorar a cintura.

Medidas: \varnothing 1.848 x 1.643 x 1.364 mm.
Zona de segurança: \varnothing 4.844 mm.

-CA- 

Reforç de la musculatura abdominal i lumbar, millorant la flexibilitat i agilitat de la columna vertebral i articulació de maluc.

Bé per millorar la cintura.

Mesures: \varnothing 1.848 x 1.643 x 1.364 mm.
Zona de seguretat: \varnothing 4.844 mm.

-FR- 

Refoncer les muscles addominaux et lombaires, D'améliorer la flexibilité et l'agilité colonne vertébrale et la hanche.

Bon pour l'amélioration de la taille.

Mesures: \varnothing 1.848 x 1.643 x 1.364 mm.
Zone de sécurité: \varnothing 4.844 mm.