

D-12C

Reja y marco imbornal abatible

Revision: 01 - 04/06/2019

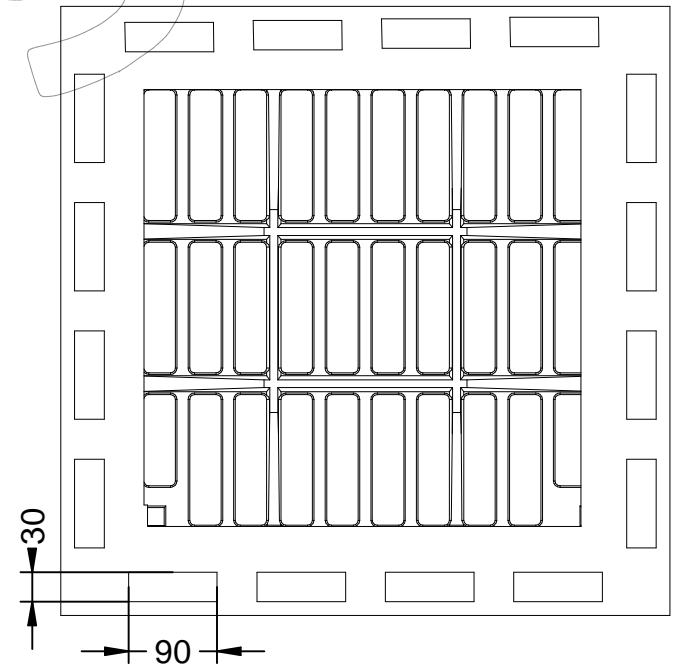
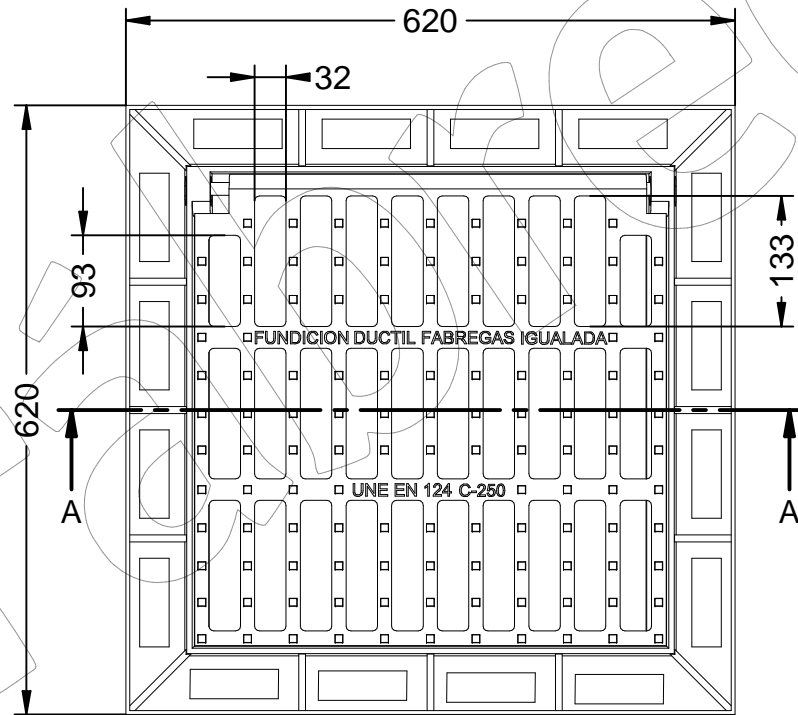
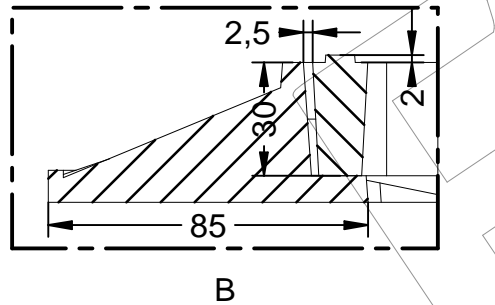
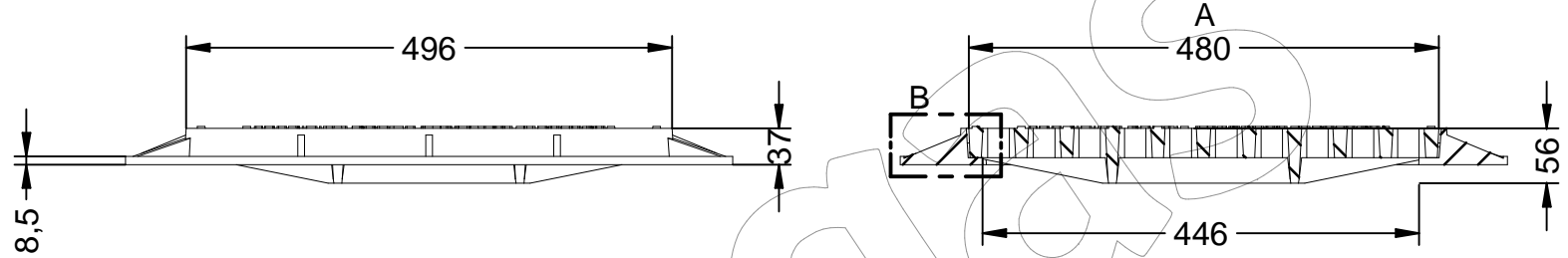

D-12C

Reja y marco imbornal abatible

Revision: 01 - 04/06/2019



-ES- 

Descripción: Reja y marco imbornal abatible.

Material: Fundición Dúctil EN-GJS-500-7.

Acabado: Pintado negro asfáltico.

Norma: UNE-EN 124.

Clase: C-250.

Embalaje: Paletizado y plastificado.

Superficie de absorción: 1.224,74 cm².

-EN- 

Description: Folding frame and scupper frame.

Material: Ductile cast iron EN-GJS-500-7.

Paint finish: Painted black asphalt.

Standard: UNE-EN 124.

Class: C-250.

Packing: Palletized and plasticized.

Absorption surface: 1.224.74 cm².

-PT- 

Descrição: Estrutura dobrável e estrutura de embeber.

Material: Ferro fundido dúctil EN-GJS-500-7.

Acabamento: Asfalto preto pintado.

Norma: UNE-EN 124.

Classe: C-250

Embalagem: Paletizado e plastificado.

Superfície de absorção: 1.224,74 cm².

-CA- 

Descripció: Reixa i marc embornal abatible.

Material: Fosa Dúctil EN-GJS-500-7.

Acabat: Pintat negre asfáltic.

Norma: UNE-EN 124.

Classe: C-250.

Embalatge: Paletitzat i plastificat.

Superfície d'absorció: 1.224,74 cm².

-FR- 

Description: Cadre pliant et cadre dalot.

Matériau: Fonte ductile EN-GJS-500-7.

Finition: Asphalte noir peint.

Standard: UNE-EN 124.

Classe: C-250.

Emballage: Palettisé et plastifié.

Surface d'absorption: 1.224,74 cm².