

A-700

Noray para 6 Tn - 12 Kgrs.

Revision: 01 - 08/01/2018

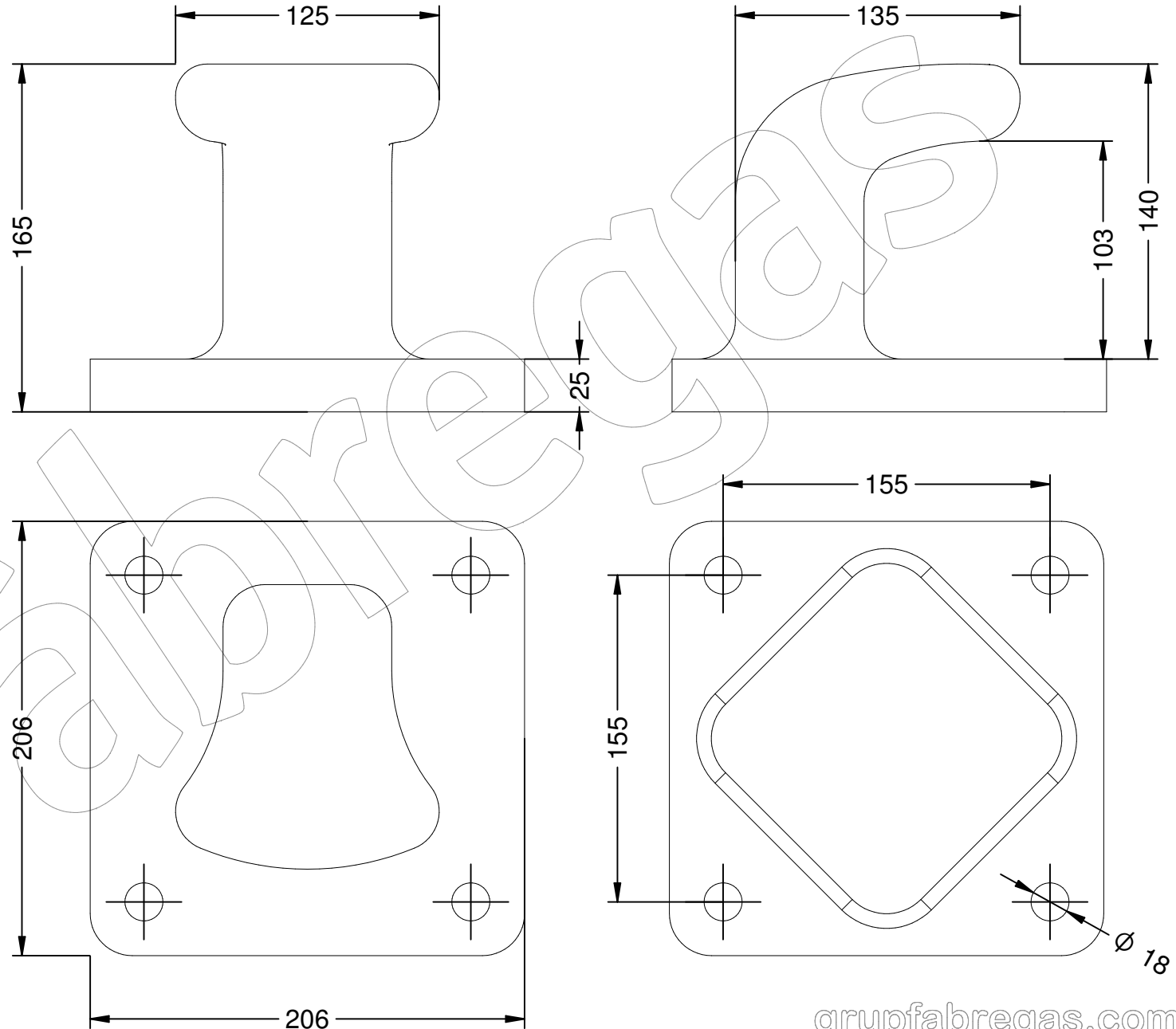

A-700

Noray para 6 Tn - 12 Kgrs.

Revision: 01 - 08/01/2018



-ES- 

Descripción: Noray de 12 Kg.

Material: Hierro, Fundición gris tipo 20.

Tiro: 6 Tn.

Acabado: Pintado poliéster al horno.

Anclaje mediante:

4 tornillos de M.16 de 300 mm de longitud con arandela y tuerca.

-EN- 

Description: Noray of 12 Kg.

Material: Iron, Type 20 gray cast iron.

Shot: 6 Tn.

Paint finish: Painted polyester baked.

Anchorage by:

4 M.16 screws of 300 mm length with washer and nut.

-PT- 

Descrição: Noray of 12 Kg.

Material: Ferro, ferro fundido cinzento Tipo 20.

Disparo: 6 Tn.

Acabamento: Poliéster pintado ao pó.

Anchorage por:

4 parafusos M.16 de 300 mm de comprimento com lavadora e porca.

-CA- 

Descripció: Noray de 12 Kg.

Material: Ferro, Fosa gris tipus 20.

Tir: 6 Tn.

Acabat: Pintat poliéster al forn.

Anclatge mitjançant:

4 cargols de M.16 de 300 mm de longitud amb volandera i femella.

-FR- 

Description: Noray de 12 Kg.

Matériau: Fer, fonte grise de type 20.

Tir: 6 Tn.

Finition: Polyester peint au four.

Ancrage par:

4 vis M.16 de 300 mm de longueur avec rondelle et écrou.